

SERVICE MANUAL & PARTS LIST

SEW MINI

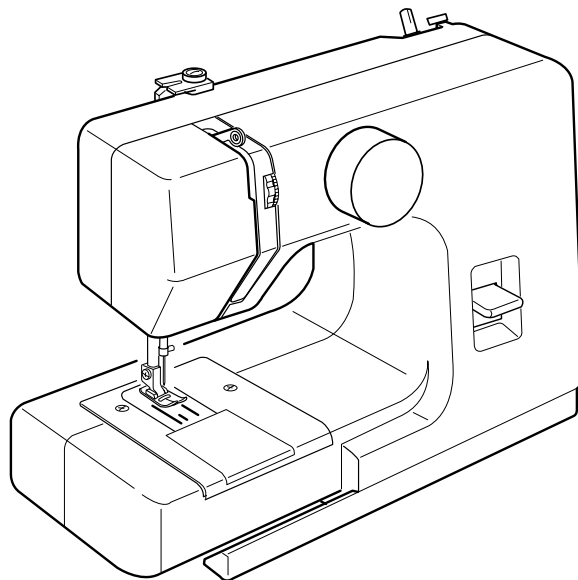

JANOME

CONTENTS

SERVICE ACCESS (1)	
FACE COVER	1
SERVICE ACSESS (2)	
FRONT COVER	2
ADJUSTING THREAD TENSION	3
ADJUSTING NEEDLE DROP POSITION	4
ADJUSTING NEEDLE SWING	5
ADJUSTING NEEDLE TO HOOK TIMING	6
ADJUSTING CLEARANCE BETWEEN NEEDLE AND HOOK POINT	7
ADJUSTING NEEDLE BAR HEIGHT	8
ADJUSTING STITCH LENGTH	9
DISENGAGEMENT OF CAM FOLLOWER	10
ADJUSTMENT MOTOR BELT TENSION	11
SETTING POSITION OF PARTS ON UPPER AND LOWER SHAFT	12
PARTS LIST	13~18

SERVICE ACCESS (1)

FACE COVER

1. Remove the face cover by removing the setscrew (A).

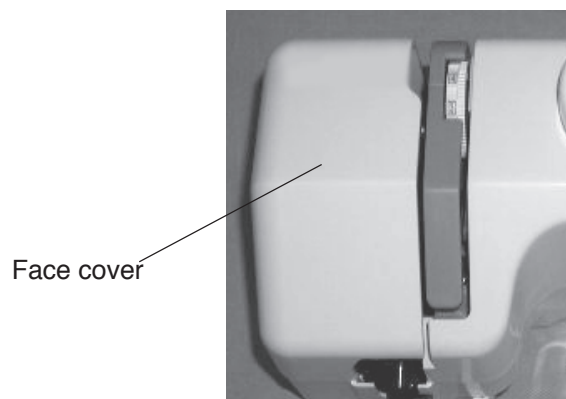
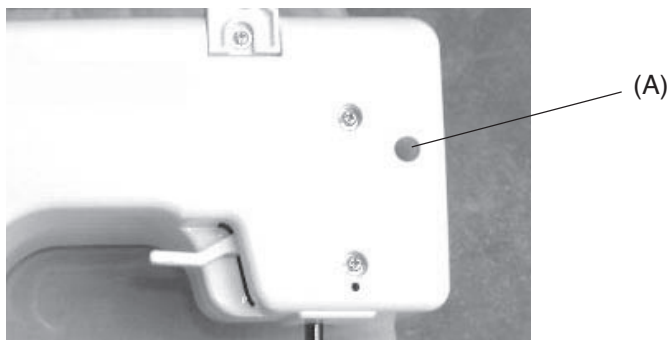

SERVICE ACCESS (2)

FRONT COVER

TO REMOVE

1. Remove the face cover.
2. Pull out the dial and remove the set screws (A) - (E).
3. Loosen the set screws (F) - (G).
4. Remove the front cover.

NOTE: Do not remove the set screws (H).

TO ATTACH

5. Follow the above procedure in reverse.

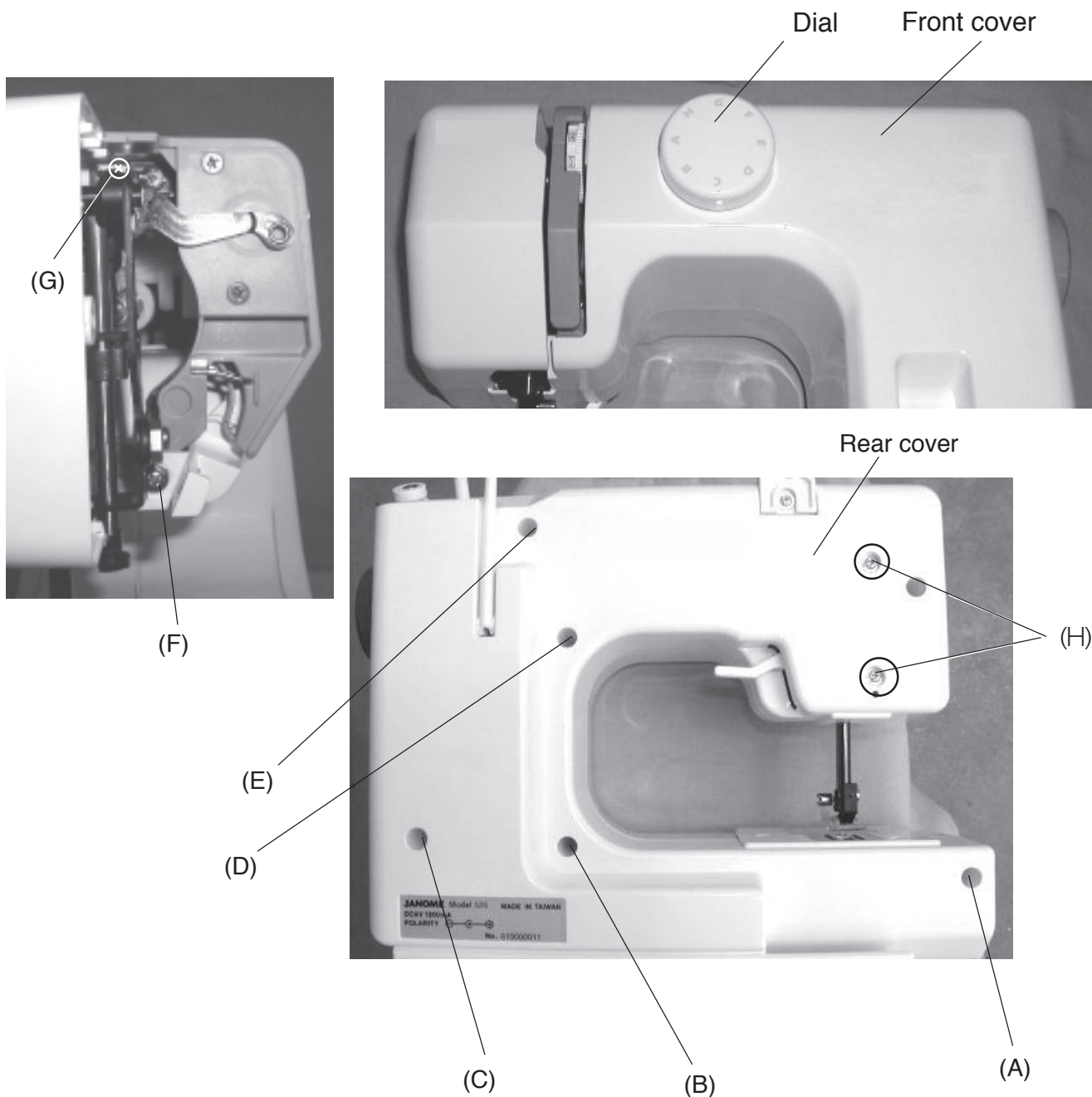

ADJUSTING THREAD TENSION

TO CHECK

The standard upper thread tension should be 75 - 90g when pulling the thread (polyester thread #50) with setting the tension dial at "4".

(Make sure the foot should be lowered.)

If the tension is out of the standard range, adjust it as follows:

TO ADJUST

1. Remove the face cover and the front cover.
2. Turn the adjusting screw (C) in the direction of (A) when the upper thread tension is too tight.

Turn the adjusting screw (C) in the direction of (B) when the upper thread tension is too loose.

3. Attach the front cover and the face cover.

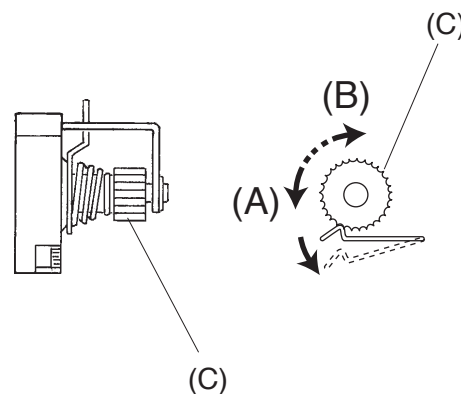
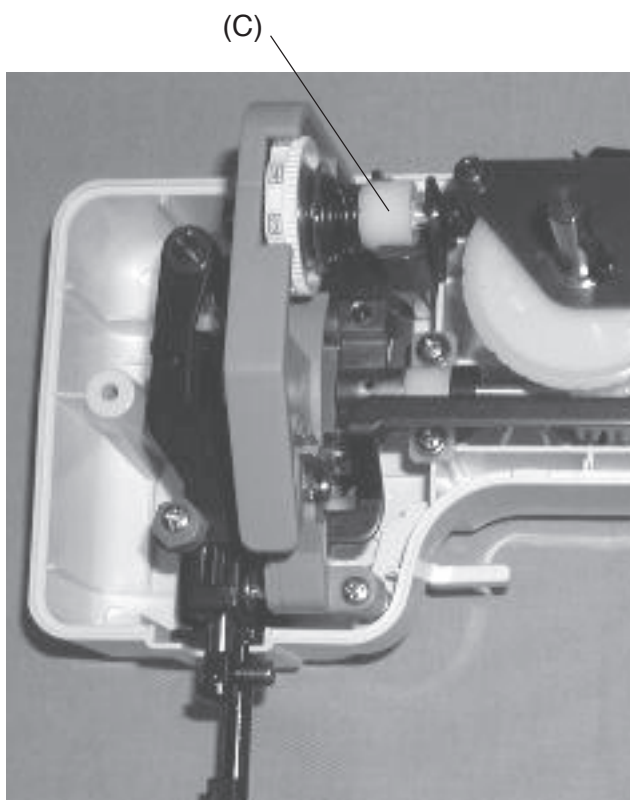

ADJUSTING NEEDLE DROP POSITION

The clearance between the needle and side edges of the needle hole should be 0.2 mm or more when the maximum width zigzag stitch (Z) is selected.

And the needle should drop in the center of the needle hole when the straight stitch is (C) selected.

TO ADJUST

1. Remove the face cover.
2. Select the straight stitch (C) and the zigzag stitch (Z).
3. Loosen the setscrew (A) and adjust the needle drop position by turning the eccentric pin (B).

NOTE: Adjust the direction of eccentric in the lower side.

4. Tighten the setscrew (A).
5. Attach the face cover.

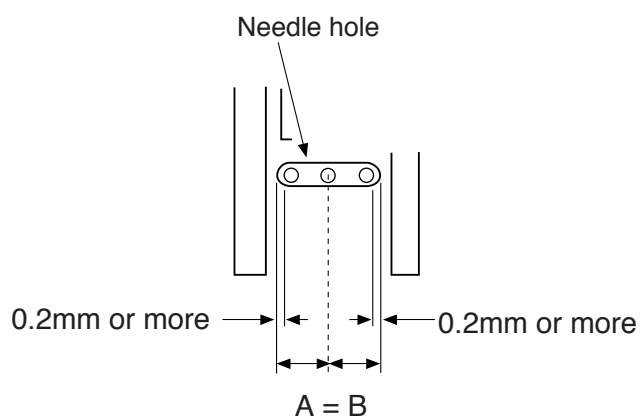
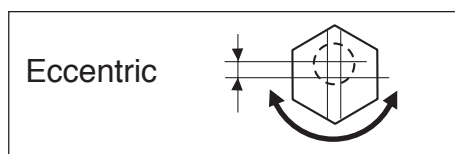
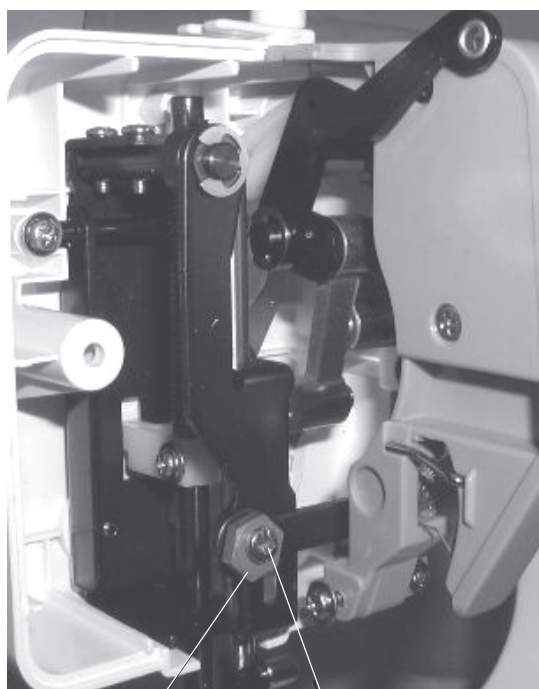

ADJUSTING NEEDLE SWING

TO CHECK

Adjust the needle swing according to the following procedure, if the needle bar starts moving sideways while the needle is in the fabric when sewing the zigzag pattern (\gtrsim) (with maximum zigzag width).

TO ADJUST

1. Remove the front cover.
2. Set the pattern selector dial at maximum zigzag width (\gtrsim).
3. Loosen two setscrews.
4. Adjust the needle swing by turning the handwheel, while holding the worm so as not to rotate it, until the needle swing starts at 1.2mm above the needle plate after the needle has come out of the right side of the needle hole.
5. Tighten two setscrews.
6. Mount the front cover.

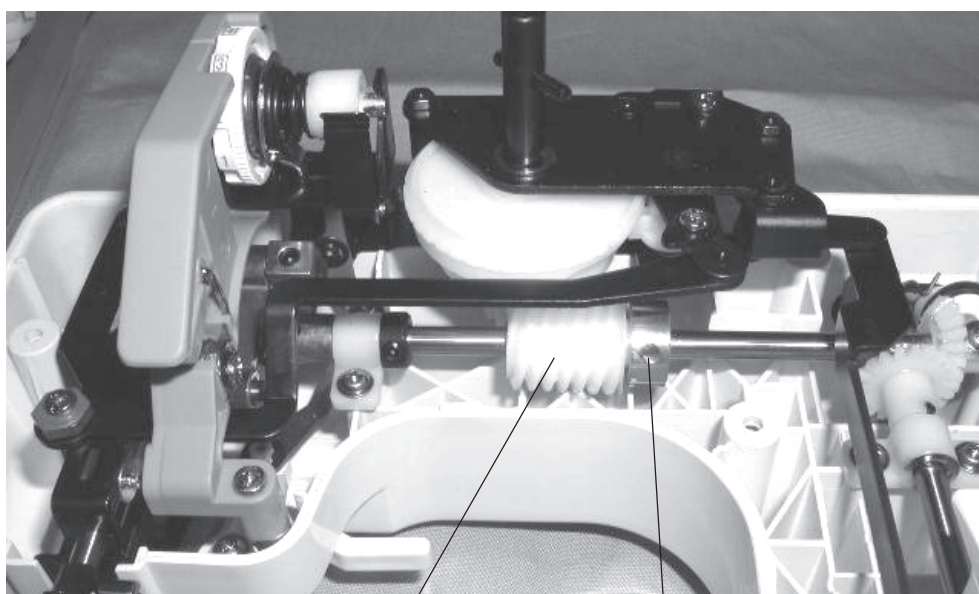

Upper shaft worm

Setscrew (2 PCS.)

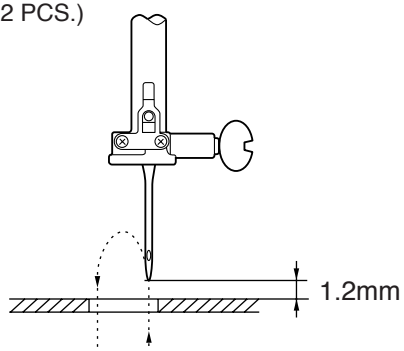

ADJUSTING NEEDLE TO HOOK TIMING

The amount of ascending travel of the needle from the right lowest position to where the hook point meets the right side of the needle should be 1.7 to 2.3mm in the maximum width zigzag stitch (\approx).

TO ADJUST

1. Select the maximum width zigzag stitch (\approx).
2. Remove the presser foot, needle plate (A) and bobbin holder (B).
3. Remove the front cover.
4. Turn the handwheel toward you to bring the needle to the right lowest position.
5. Loosen the 2 setscrews (C) on the lower shaft gear.
6. Raise the needle 2.0mm from the lowest position.
7. While holding the handwheel as not to move the needle bar, rotate the hook race until the hook point meets the right side of the needle.
8. Tighten the 2 setscrews (C).
9. Attach the front cover.
10. Attach the bobbin holder, needle plate and presser foot.

NOTE: Match the bobbin holder convex part (D) to the edge of needle plate base (E) when attach the needle plate.

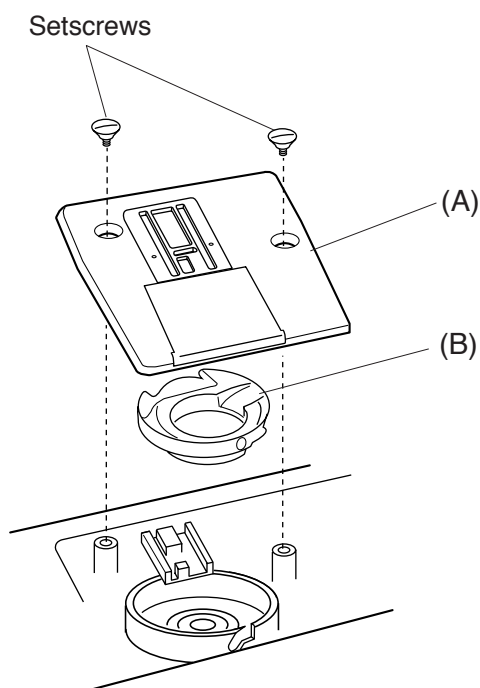

(Bobbin holder normal position)

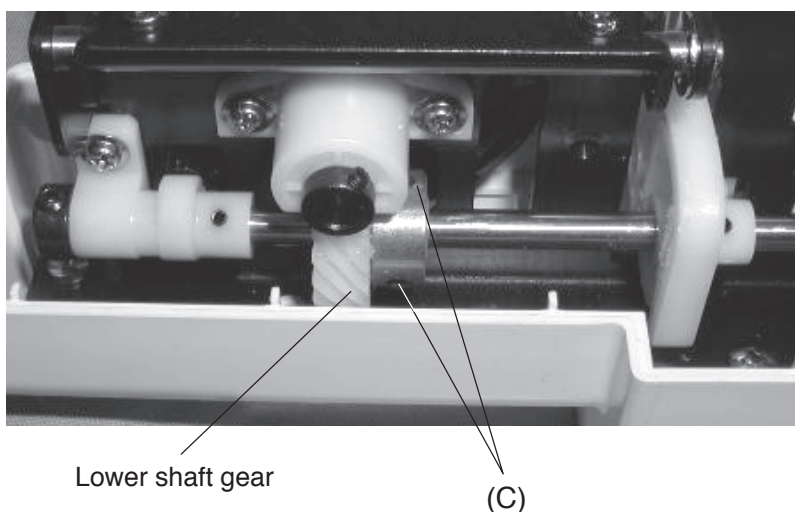
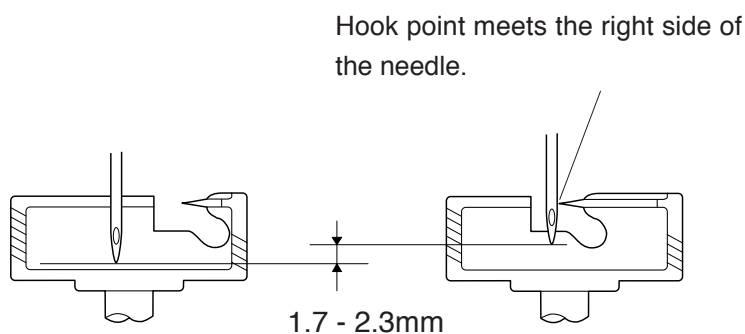
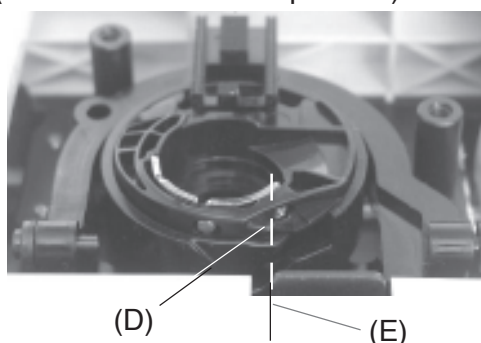

ADJUSTING CLEARANCE BETWEEN NEEDLE AND HOOK POINT

The standard clearance between the needle and hook point should be -0.10 to +0.05 mm.

TO ADJUST

1. Select the maximum width zigzag stitch (\sum).
2. Remove the presser foot, needle plate (A) and bobbin holder (B).
3. Turn the handwheel toward you to bring the hook point behind the needle.
4. Loosen 2 setscrews (C) and adjust the clearance by turning the screw (F) in and out.
5. Tighten 2 setscrews (C).
6. Check the clearance in the right and left needle positions.
7. Attach the bobbin holder, needle plate and presser foot.

NOTE: Match the bobbin holder convex part (D) to the edge of needle plate base (E) when attach the needle plate.

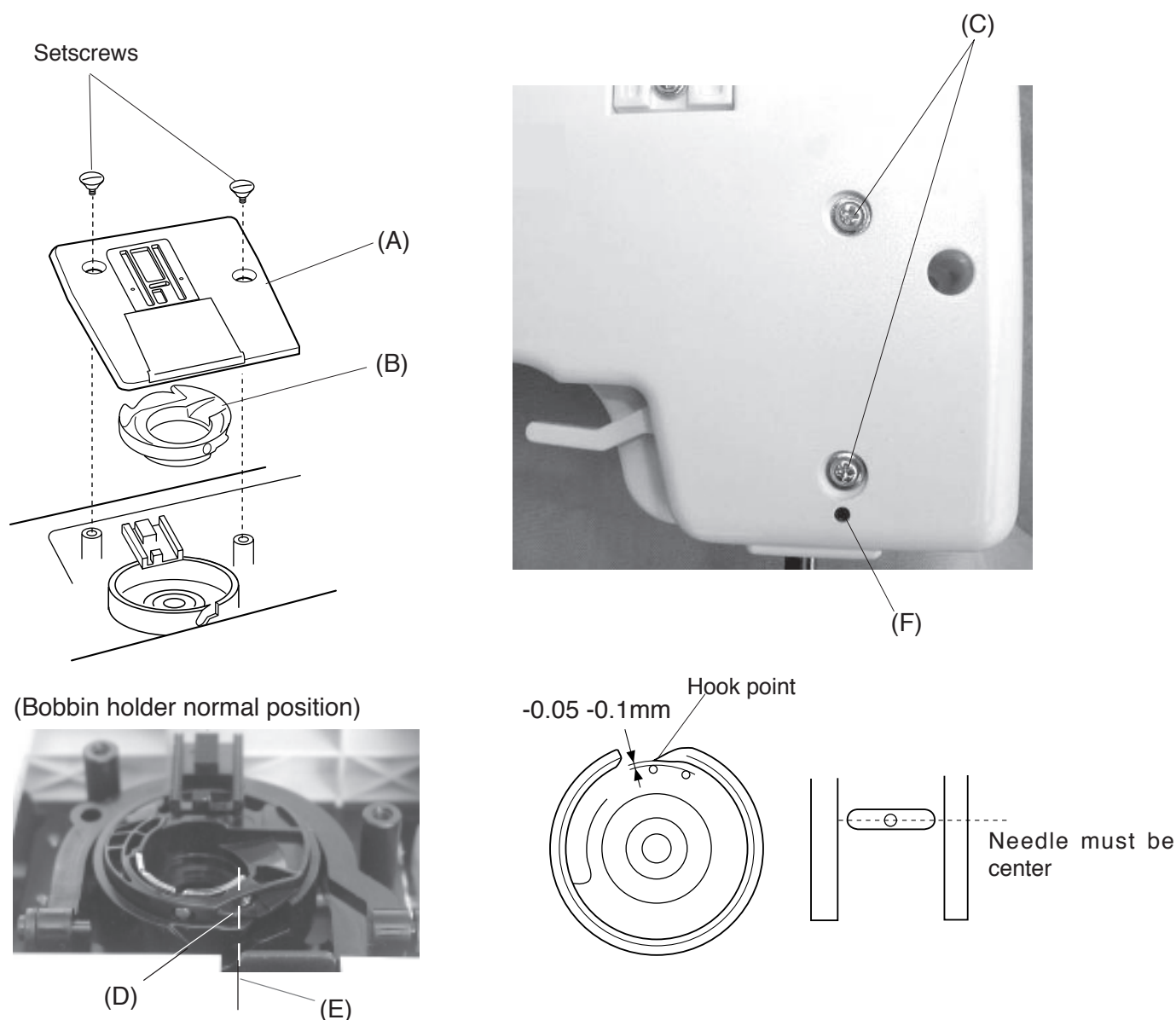

ADJUSTING NEEDLE BAR HEIGHT

The standard distance between the upper edge of the needle eye and the upper surface of the hook race should be in the range of 2.7 - 3.3mm when the hook point meets the right side of the needle in its ascending travel from the right lowest position of the maximum width zigzag stitch (>).

NOTE: Before performing this adjustment, check the needle to hook timing.

TO ADJUST

1. Select the maximum width zigzag stitch (>).
2. Remove the presser foot, needle plate (A) and bobbin holder (B).
3. Turn the handwheel toward you until the hook point meets the right side of the needle.
4. Remove the face cover and loosen the setscrew (C).
5. Move the needle bar up or down to adjust the needle bar height.

NOTE: Be careful not to rotate the needle bar.

6. Tighten the setscrew (C).
7. Attach the face cover, bobbin holder and needle plate.

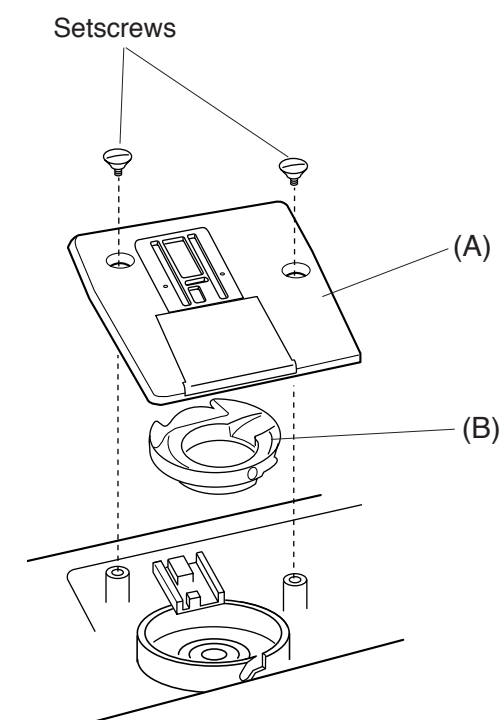

(Bobbin holder normal position)

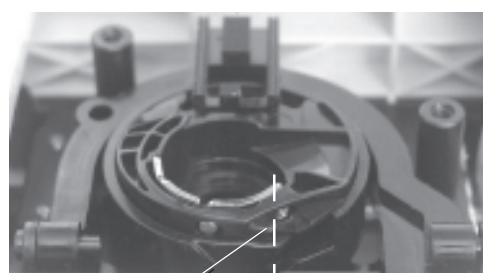

(D) (E)

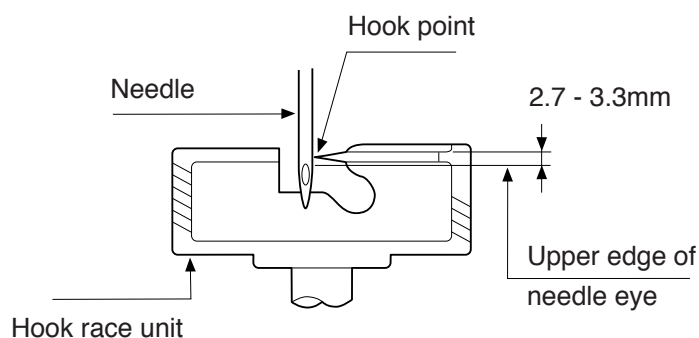
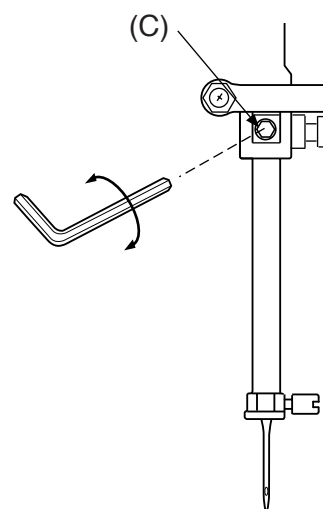

ADJUSTING STITCH LENGTH

When select the maximum stitch (|), stitch length should be 3.0mm.

TO ADJUST

1. Set the pattern selector dial at maximum stitch length (|).
2. If the stitch length is longer than 3.0mm, turn the adjusting screw in the direction (A).
If the stitch length is shorter than 3.0mm, turn the adjusting screw in the direction (B).

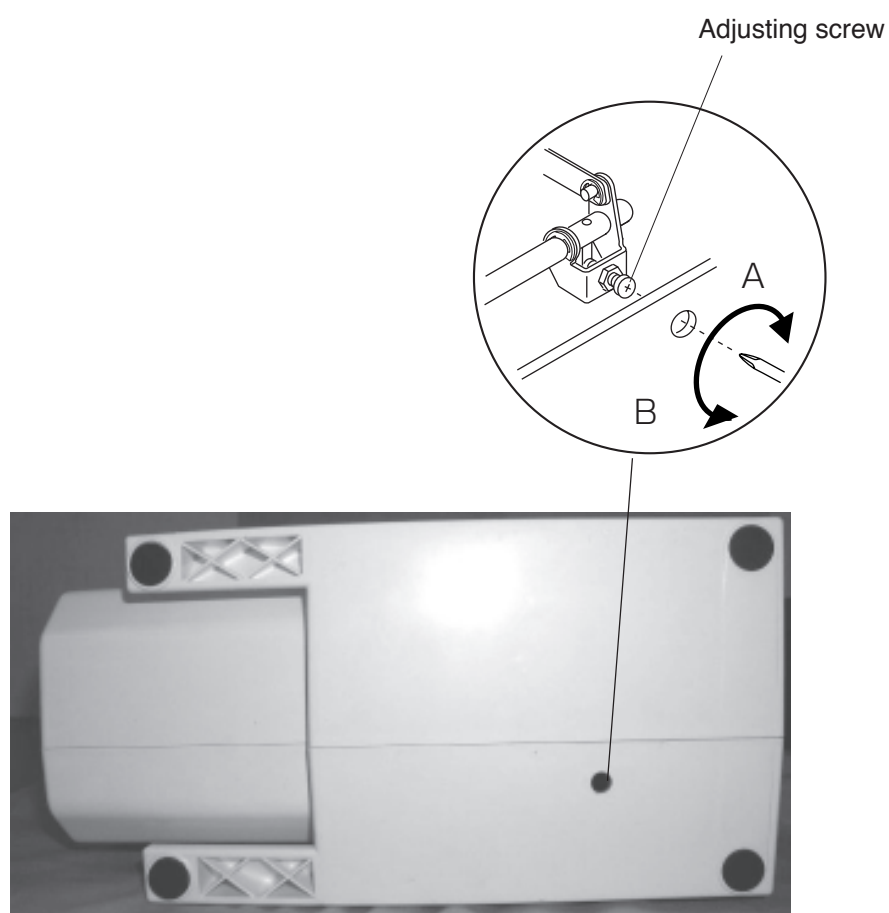

DISENGAGEMENT OF CAM FOLLOWER

TO CHECK

Too narrow clearance between the cam follower and the top convex of zigzag cam may often cause difficulty in turning of the pattern selector dial, or can not correct pattern.

1. Set the pattern selector dial at " C | > ".
2. Remove the face cover and front cover.
3. Turn the hand wheel toward you and put the cam follower to the zigzag cam.
4. Loosen the setscrew.
5. Move adjusting plate in the direction of arrow until to touch to the releasing arm and tighten setscrew.

- NOTE:** After this adjustment, check that the clearance between the zigzag cam and the cam follower is 0.3mm when putting the cam follower releasing arm onto position (A) of pattern select cam.
6. Attach the front cover and face cover.

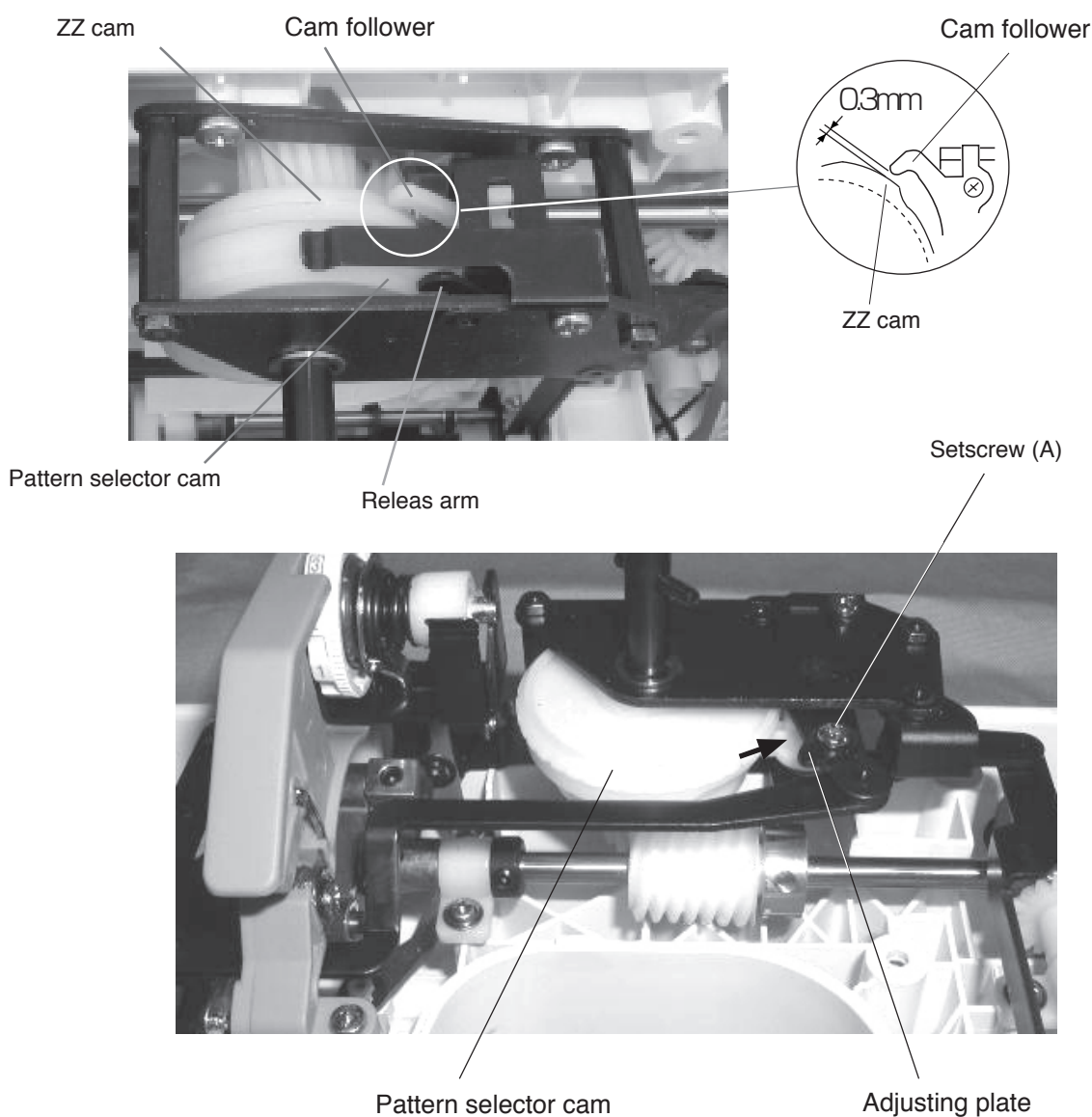

ADJUSTING MOTOR BELT TENSION

The correct motor belt tension is when the deflection of motor belt is about 7mm - 9mm.
(When pushing the motor belt by finger with a 100 gram load.)

TO ADJUST

1. Remove the face cover and front cover.
2. Loosen the setscrews (A) and (B) and adjust the deflection.
4. Tighten the setscrews (A) and (B).

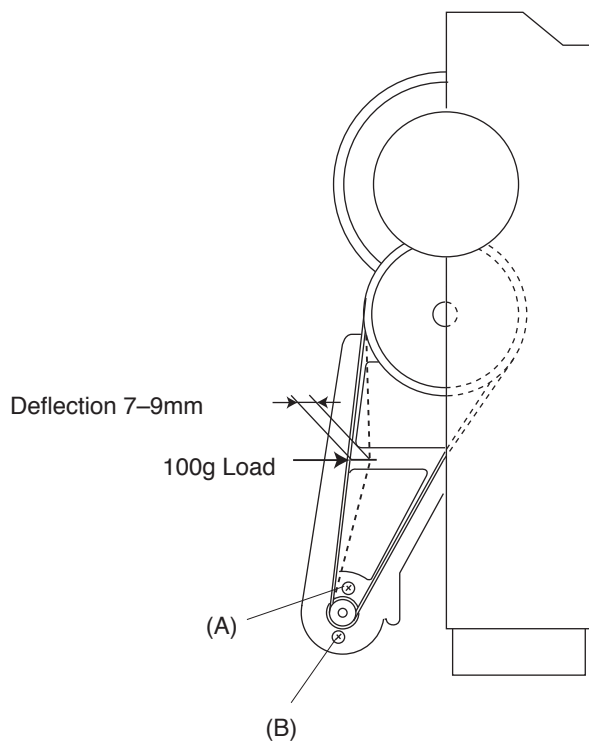

SETTING POSITION OF PARTS ON UPPER AND LOWER SHAFT

The setting positions of the parts on the lower shaft are as shown below.

The setting angle of the upper shaft bevel gear setscrew (A), lower shaft bevel gear setscrew (B) and the feed cam (C) setting mark should be at the top when needle bar comes to it's lowest position.

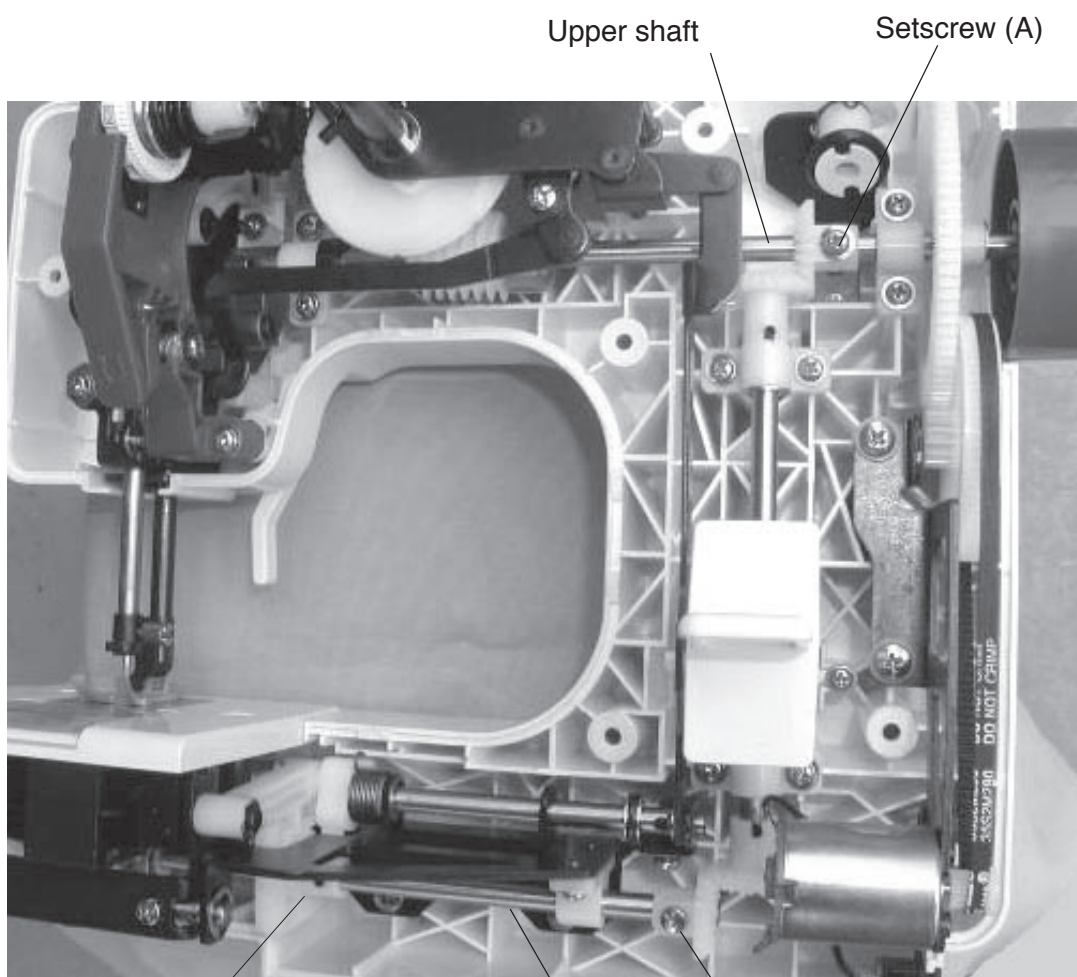

Feed cam (C)

Lower shaft

Setscrew (B)



Setting mark

PARTS LIST

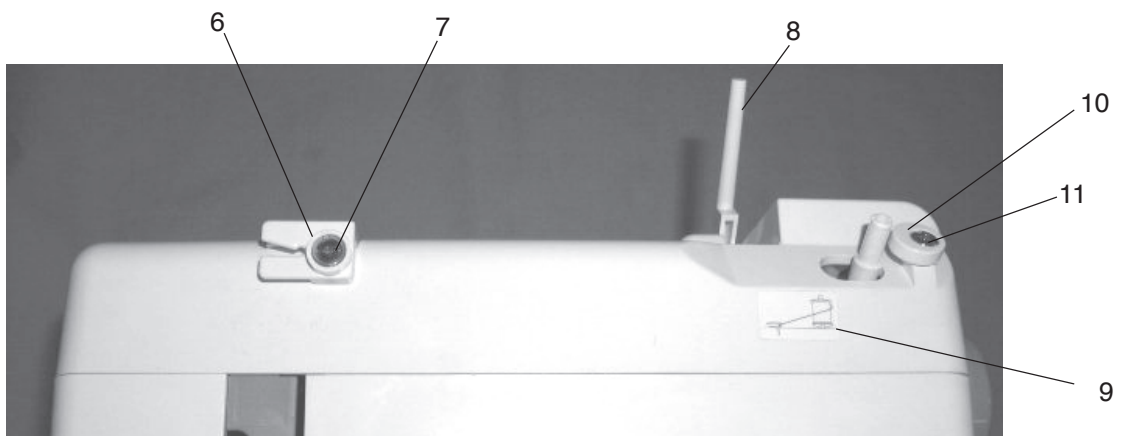
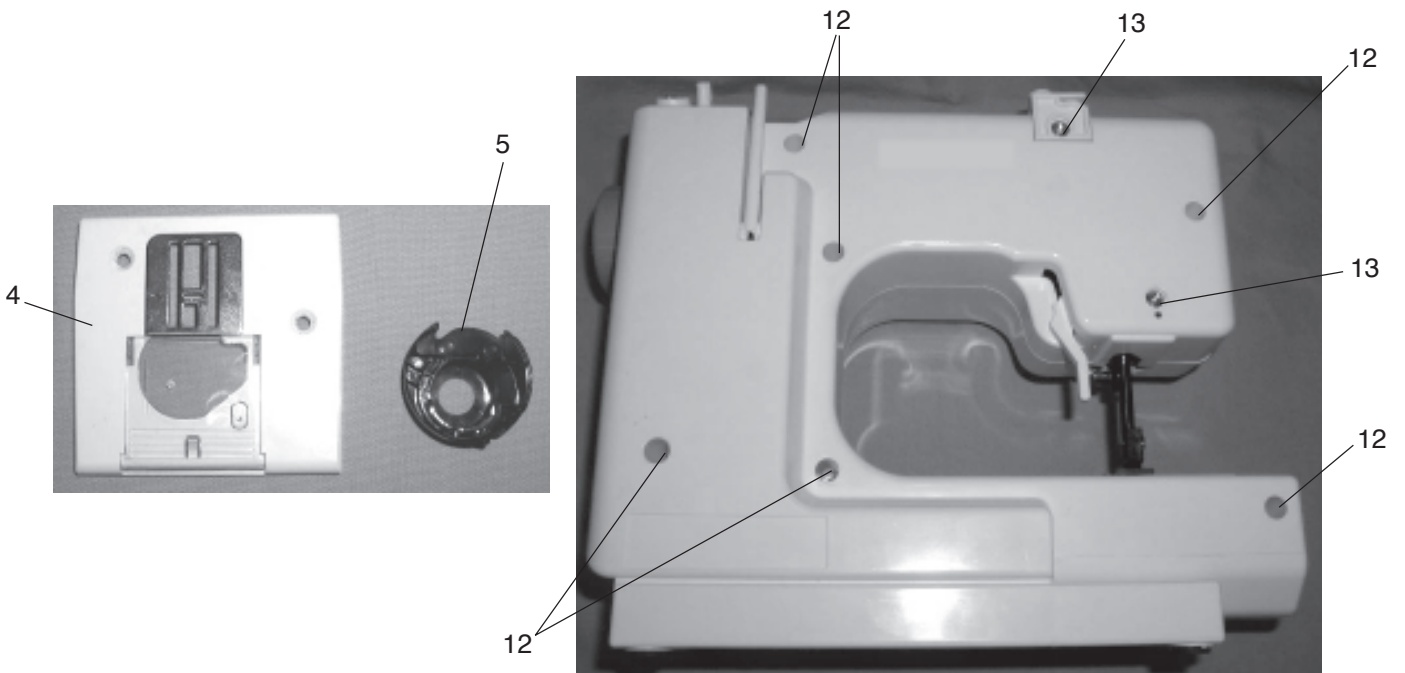

KEY NO.	PARTS NO.	DESCRIPTION
1	525084103	Face cover
2	525623100	Front cover unit
3	525073202	Selector dial
4	525617008	Needle plate unit
5	525618009	Bobbin holder unit
6	525603001	Thread guide unit
7	000149301	Set screw 3 x 8
8	639003001	Spool pin
9	525094003	Sticker
10	735016307	Bobbin winder stopper
11	000101817	Set screw 4 x 16
12	000161309	Set screw 3 x 12 (b)
13	000115201	Set screw 3 x 8

PARTS LIST

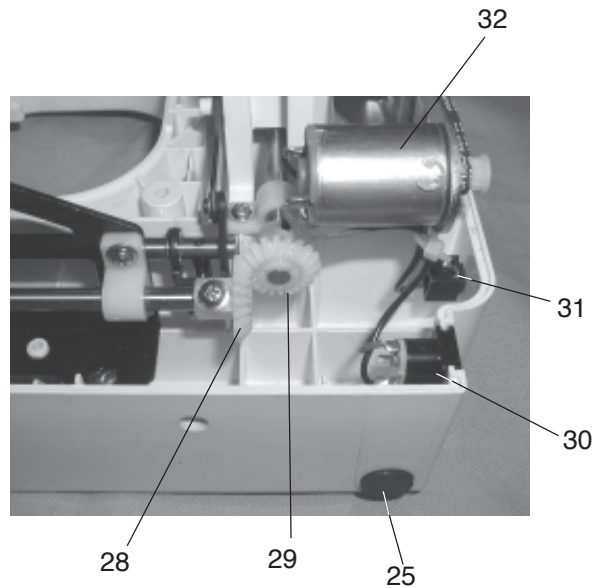
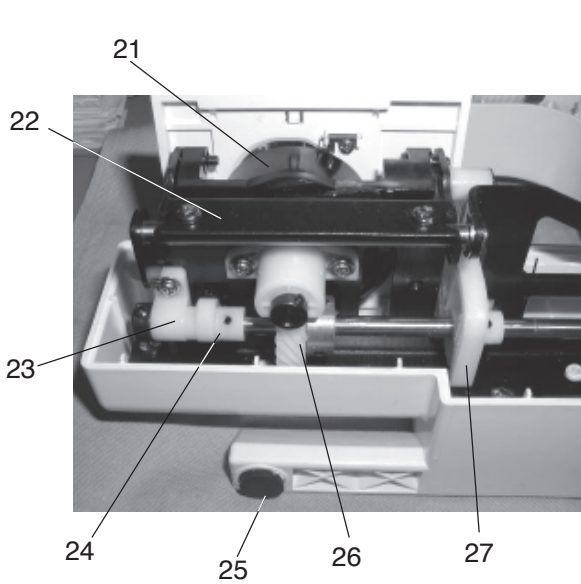
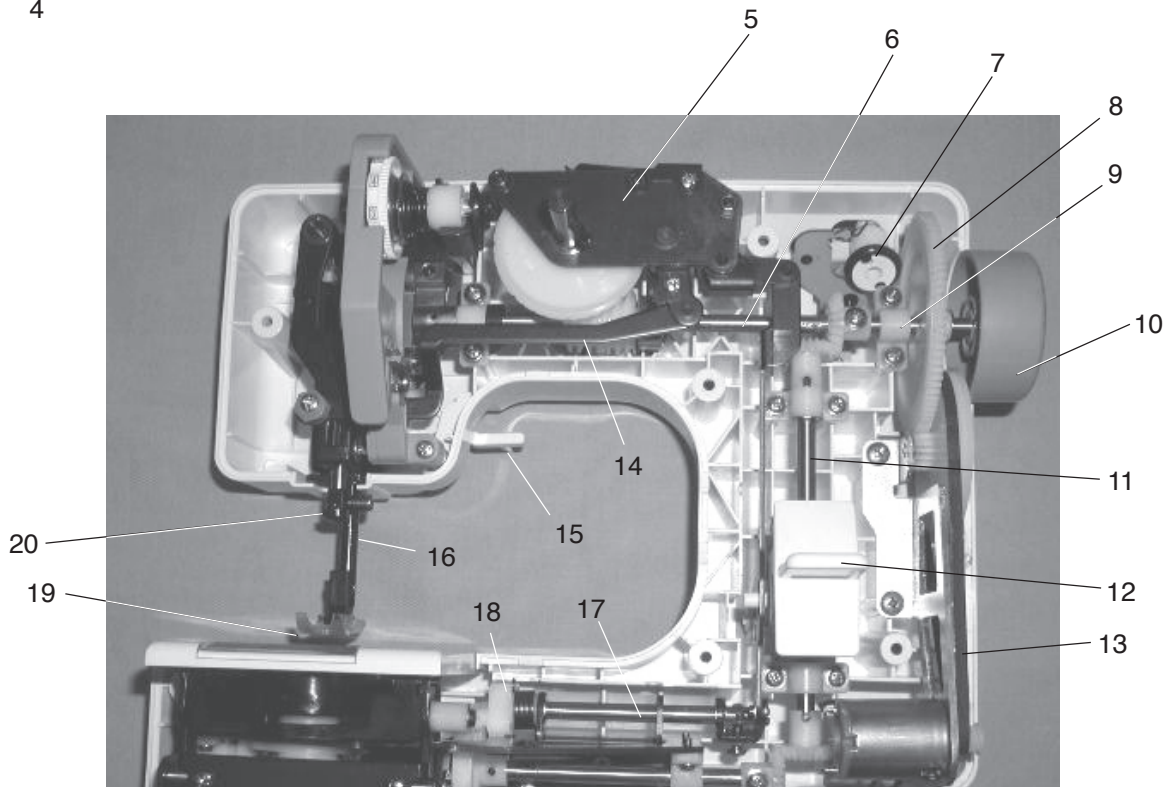
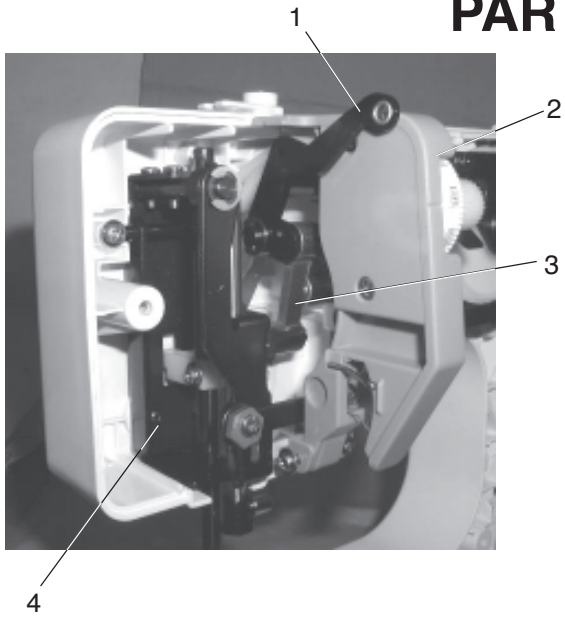

KEY NO.	PARTS NO.	DESCRIPTION
1	525608006	Thread take up lever unit
2	525502205	Thread tension regulator unit
3	525028006	Needle bar crank rod
4	525604002	Presser base plate unit
5	525619000	Cam block unit
6	525609100	Upper shaft unit
7	525624008	Bobbin winder base unit
8	525081007	Gear
9	525031002	Bearing
10	525035202	Hand wheel
11	525610001	Vertical shaft unit
12	525074007	R lever
13	525082008	Belt 290
14	525071004	Zigzag rod
15	525002004	Presser foot lifter
16	525013008	presser bar
17	525615006	Feed shaft unit
18	525054001	Feed regulator unit
19	525501008	Presser foot unit
20	525606004	Needle bar unit
21	525612003	Hook unit
22	525614005	Feed base unit
23	525046000	Lower shaft bearing
24	525045009	Feed lifting cam
25	525010005	Base rubber
26	525044008	Lower shaft gear
27	525052009	Feed forked rod
28	525033004	Gear A
29	525037008	Gear B
30	525504001	Power supply jack
31	525505002	Foot switch jack unit
32	525621005	DC motor unit (100V)
	525621108	DC motor unit (220V)

PARTS LIST

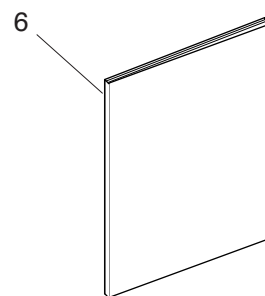
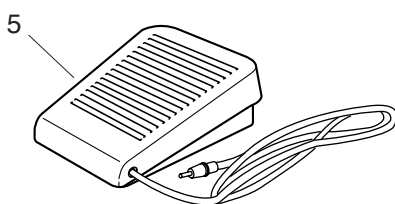
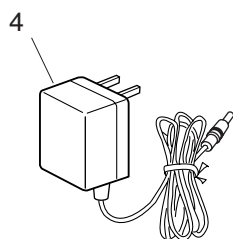
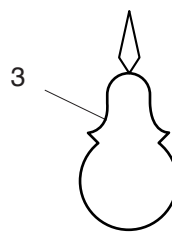
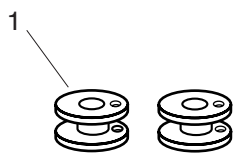

KEY NO.	PARTS NO.	DESCRIPTION
1	102261000	Bobbin
2	525809009	Needle
3	525810003	Needle threader
4	525808008	AC adaptor unit (110V)
	525813006	AC adaptor unit (220V)
5	525801001	Foot switch unit
6	525800217	Instruction book